



# 深圳市中科世纪科技有限公司

## 产品规格书

### Product Specification

产品型号: 无刷直流水泵 DC65A

发布日期: \_\_\_\_\_

版本号: V1.0

供方 VENDOR			客户 CUSTOMER		
编制 PREPARED	审核 CHECKED	批准 APPROVED	编制 PREPARED	审核 CHECKED	批准 APPROVED

深圳市中科世纪科技有限公司

shenzhen zhongke century technology co,ltd

深圳市宝安区潭头西部工业园区编号 B33 栋

No. B33, Western Industrial Park,

Tan Tou, Bao'an District, Shenzhen City

Tel:86-755-27811557

Fax:86-755-27811571

[www.microwaterpump.com](http://www.microwaterpump.com)

[www.smalldc泵.com](http://www.smalldc泵.com)

## 一. 产品特征简介 Product Features

1	产品名称 Product name:	无刷直流水泵 DC65A Brush-less dc pump DC65A
2	型号 Model No:	DC65A
3	重量 Weight:	1.3kg
4	寿命 Life span:	≥30000h(连续 continuous)
5	防护等级 Waterproof Grade:	IP68
6	颜色 Color:	黑色 Black
7	认证 Certificate:	CE,ROSH
8	壳体材料 Material of pump	PPS+30%GF
9	噪音 Noise class:	≤35dB
10	工作压力 Bearing pressure:	≤0.6MPa
11	绝缘等级 Insulation grade:	H Grade (180°)
12	工作原理 Working principle:	离心泵 Centrifugal pump
13	用途 Application:	电动汽车散热系统, 循环散热系统 ECO Car cooling system, Cooling circulation system

## 二. 应用范围 Range of application

1	使用液体类型: Liquid Type:	油性介质, 水, 酸碱盐以及其他流动性液体 Water, oil, or normal acid/ alkaline and other liquids(need to test)
2	使用液体温度: Liquid Temperature:	-30° —100° (超过 80° 需特殊定制) -30°—100°(Above 80° need special customization)
3	调速方式: Power regulation function:	<ul style="list-style-type: none"> <li>PWM 调速: 幅值 5V 50-800HZ 可定制 Speed adjustable by PWM (5V,50~800HZ) can be customized</li> <li>0-5V 调速, 电位器 (4.7k~20K) 0~5V analogical signal or potentiometer (4.7k~20K)</li> </ul>
4	使用电源类型: Power:	直流电源, 蓄电池 PSU,Battery

## 三. 基本参数(参数可以定制) Parameter (Parameter can be customized)

1	产品型号: Product model:	DC65A-12130PWM DC65A-12130VR DC65A-12130VS DC65A-12130S	DC65A-24250PWM DC65A-24250VR DC65A-24250VS DC65A-24250S	PWM:PWM 调速 PWM speed regulation (50-800HZ/ 5V) VR:0~5V/电位器调速 potentiometer speed regulation VS:0~5V 模拟电压信号调速 Voltage signal speed regulation S:固定转速 Fixed speed
2	额定电压: Rated Voltage:	12V DC	24V DC	
3	工作电压范围: Working voltage range:	10-18V	18-28V	此范围内, 水泵能够正常工作 The pump can out put constant power when the voltage is higher than rated voltage.
4	额定电流: Rated Current:	4.3A(5.8A) ±10%	5.3A(4.8A) ±10%	封闭出水口电流 (敞口抽水电流) Closed outlet current(open outlet current)
5	输入功率: Input Power:	52W(70W) ±10%	128W(115W) ±10%	封闭出水口功率 (敞口抽水功率) Closed outlet power(open outlet power)
6	最大流量: Max. Flow rate:	1700L/H ±10%	2000L/H ±10%	敞口流量 Open outlet flow
7	最大扬程: Max. Head:	13M ±7%	25M ±7%	静态扬程 Static lift
8	推荐输入电源: Min. power supply:	12V-6A	24V-6A	
9	恒功率输出: Constant power output:	例如 12V(24V)10W 的水泵, 用 12-18V(24-30V)都是 10W,并且可以长期运转。 For example, a 12V (24V) 10w pump with 12-18V (24-30V) is 10w and suitable for a long time working under this condition		

备注:参数可以向下兼容, 例如最大 115W 可以定制 115W 以内任何参数。

#### 四. 附加功能说明 Additional function instructions

1	卡死保护 Jam protection	卡死的时候水泵停止工作 When jam it will Stop to protect itself
2	缺水/空转保护 Dry run protection	水泵缺水或者空转时水泵会循环的停转（4秒）运转（2秒），可定制保护策略 The pump will Stop(4s) and start(2s) repeatedly to protect itself(can be customized)
3	过压保护 Overloading protection	当电压不稳定或者其他原因导致超过水泵额定功率，水泵停止运行 When the voltage exceeds the rated power, the pump will stop

#### 五. 控制板位置说明

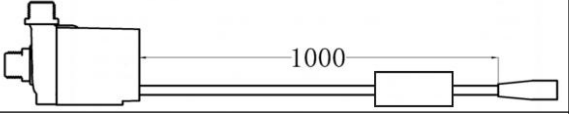
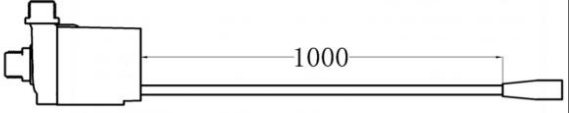
1	水泵驱动器外置 Controller External install		适合潜水或陆用场合 Suitable for submersible install or external installation
2	水泵驱动器内置 Controller Internal install		适合外置陆用场合 Suitable for external installation

#### 六. 参数测试安装示意图 Installation Drawing

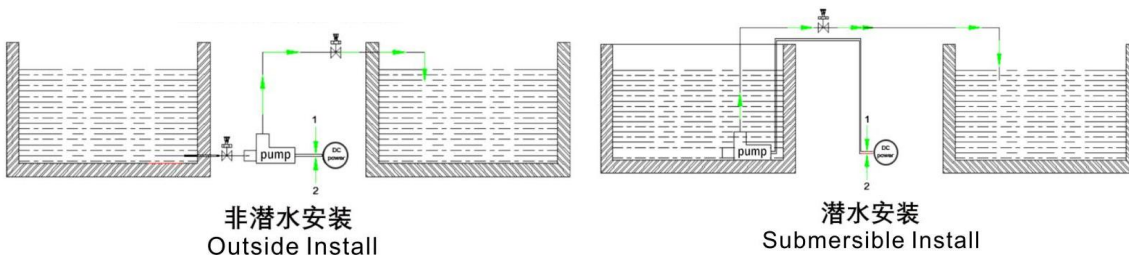

注意：本产品不具备自吸功能，因此在安装时，需要保证压盖型腔内具有足够的水，即安装时需要保证水泵中心位置低于水箱内液面，以保证水泵能够正常运行！

Notice: The pump is not self-priming pump. When install, please make sure there is enough water in pump gland. Meanwhile, the pump must be installed below the liquid level in the tank.

#### 七. 扬程-流量曲线图 Flow -Head Chart

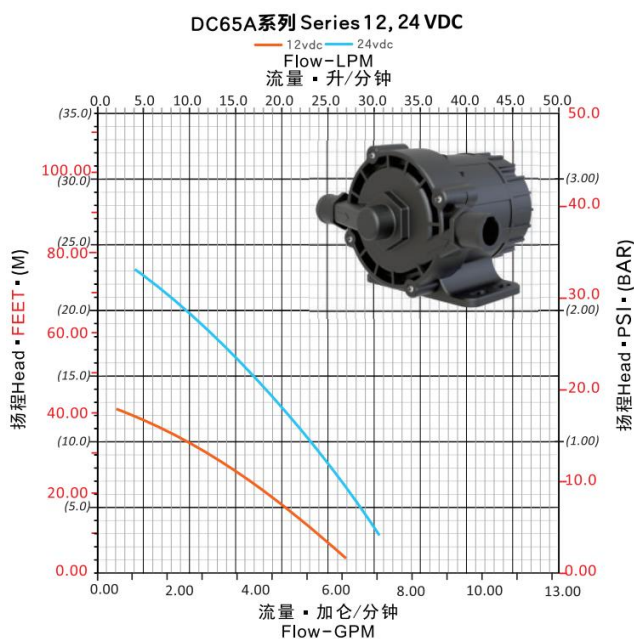

### 八. 尺寸与外观图 Dimension and appearance

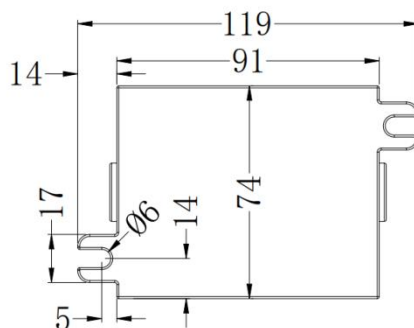
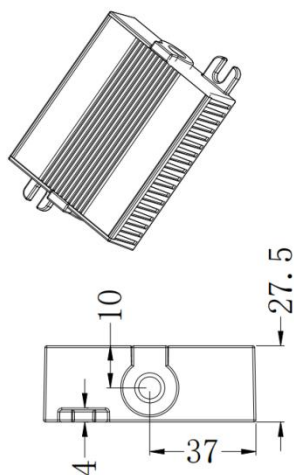
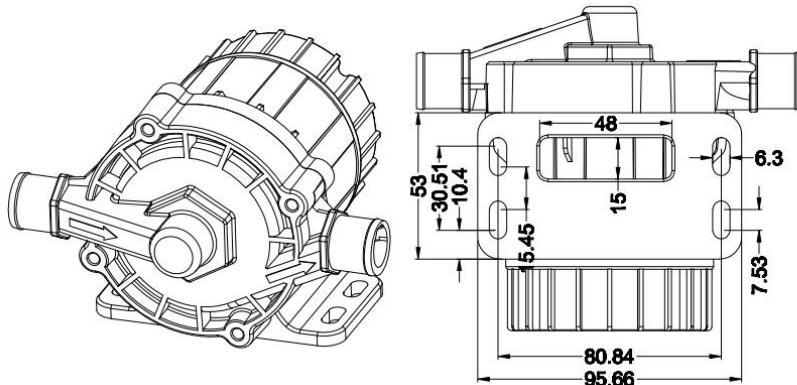
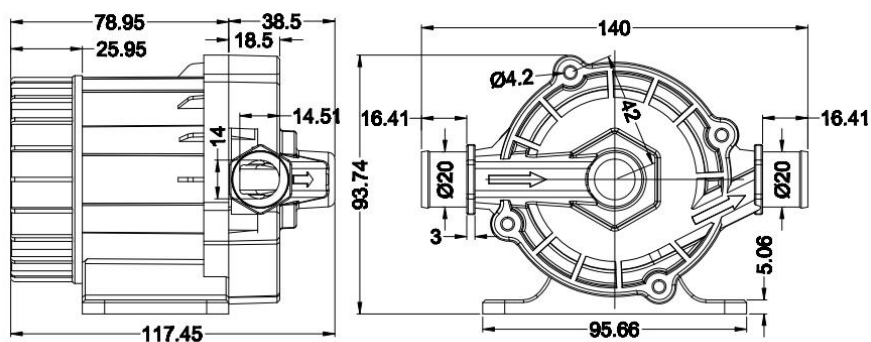

## 九. 故障与维修 Failure and maintenance

	故障现象 Failure phenomenon	原因 Cause	解决方案 Solution
1	电流大, 流量小 High current, low flow	转子内有杂质 Impurities in the rotor	拆开水泵清洗转子 Disassemble the pump to clean the rotor
2	电流变小, 抽水断续 pumping intermittent Current becomes low,	缺水 What shortage	加水 Add water
3	不转, 电流时大时小 No rotation, current is high and low	转子因异物卡死 Rotor jammed by a foreign object	排除转子卡死异物 Remove foreign matter from rotor
	不转, 出现短路电流 No rotation, short-circuit current	控制板损坏 Damaged control board	更换水泵 Change a new pump
	不转无电流 No current without rotation	电源线没有接好 The power cord is not connected.	检查连接件或插头是否正常 Check if connected
4	噪音大 Noisy	泵内有杂质 Impurities in the pump	排除杂质 Remove impurities
		泵内有气体无法排出 air in the pump cannot be discharged	将出水口朝上放置, 使液体中没有空气 Place the outlet facing up so that there is no air in the liquid
		泵内无液体, 水泵干磨 No liquid in the pump, pump dry running	使泵内有液体即可 have enough liquid in the pump

## 十. 注意事项 Notice

1. 严禁使用带有大于 0.35mm 的杂质和陶磁性颗粒的液体。 It is forbidden to use liquids with impurities greater than 0.35mm and ceramic or magnetic particles.
2. 长时间不使用时, 通电前最好先使用泵内有一定的液体。 If it is not used for long time, make sure water goes inside the pump before power on.
3. 通电前请先确认连接无误, 否则可能产生故障。 If not used for long time, please make sure cord connection correctly.
4. 严禁泵内无液体时长时间使用。 Do not let pump dry run .
5. 低温环境使用时, 请确保使用液体不会出现结冰或者变得很粘稠。 If use in low temperature environment, please make sure the water won't be frozen or thick..
6. 连接器的针脚处有水渍, 请将水渍处理干净后再使用。 Please check if there is water on connection plug, and clean it before us